

SERIAL NUMBER CHIP

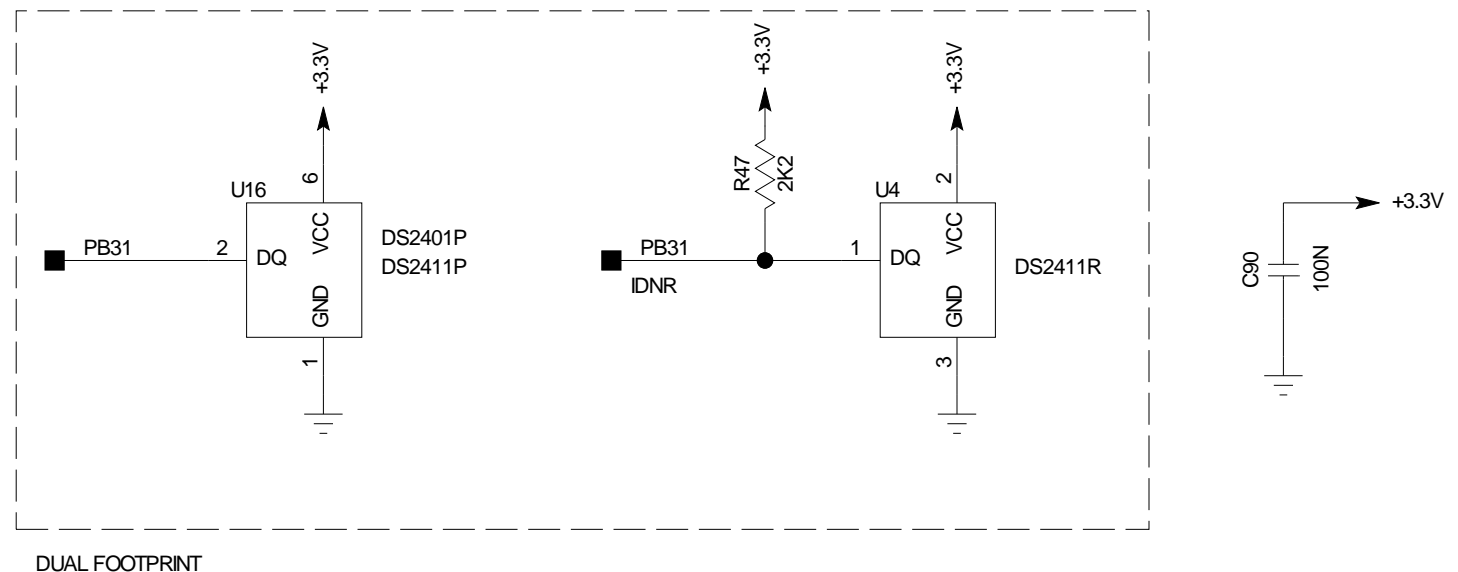

SODIMM200 CONNECTOR

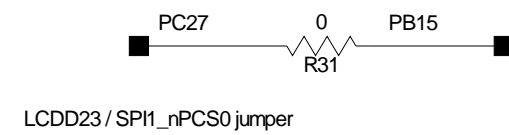
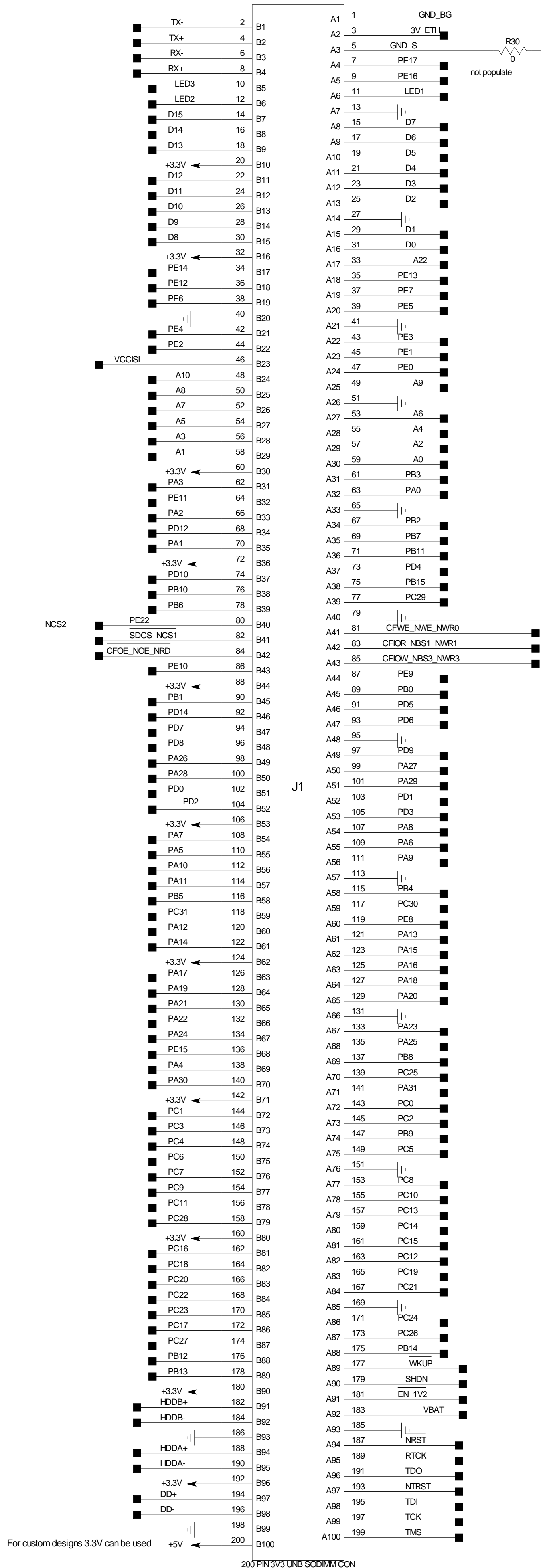

For custom designs 3.3V can be used +5V

200 PIN 3V3 UNB SODIMM CON